



10 Amp PWM Electric Motor Driver

Kit 18108

The Electric Motor Driver Module (EMD) replaces the servo valve. System flow is controlled by regulating the pump speed via PWM signal.

⚠ This unit ONLY works with PWM (Pulse Width Modulated) Control drives. Set the controller PWM frequency to 100 Hz.

EMD Module Installation

⚠ Be sure to route cables away from sharp edges, heat sources, and moving parts - and secure cabling with plastic ties.

⚠ Mounting surfaces must be cleaned free from dirt, moisture and oil residues. Failure to clean the mounting surface may result in adhesive failure.

Find a location that makes routing wiring as simple and direct as possible. Peel off the backing from the included adhesive strip, press it firmly to the bottom of the module, then peel off the other backing and press the module in place. As a precaution, also secure the module with plastic cable ties. This prevents it from contacting any moving parts if it vibrated loose. Alternatively, the module can be fastened with screws through the holes in the mounting flanges.

Electrical Installation

The EMD **MUST** be connected to a 12VDC negative ground electrical system. **Note:** battery terminal connections must be clean with solid metal-to-metal contact.

1. Power Cable to Battery Connection

Find 20' Power Cable PN18137 and route to the battery. Join the BLACK wire to ground, and join the ORANGE wire to positive battery terminal. Connect power to the EMD by plugging the 3-pin W/P tower on the power cable into the 3-pin W/P shroud of the EMD module.

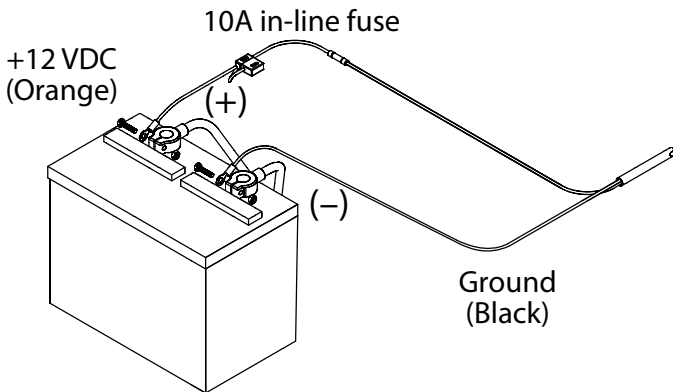

2. Control Connection

Locate the PWM control cable PN13200. Connect the 2-pin M/P150 Tower to the 2-pin M/P150 Shroud on the EMD module. Connect to the other end of the cable to the mating connector on the controller harness, using Adapter Cable P/N 17539 if required.

⚠ PN13200 polarity - Pin A = Positive, Pin B = Negative

3. Motor Connection

Locate 5' Motor Extension Cable PN14501. Plug the 2-pin W/P tower into the 2-pin W/P shroud on the EMD module. Join 2-pin W/P shroud to motor (pump). If needed, a 2-pin W/P tower mating connector is included to connect to the motor, or the connector on the 5' Ext. Cable PN14501 can be removed and wire-to-wire connection can be made. Check that the pump rotates in the correct direction. If not, simply reverse the wires.

⚠ Do not connect the motor leads to the battery or power supply. Resulting damage to module will NOT be covered under warranty.

2-pin W/P Tower mating connector

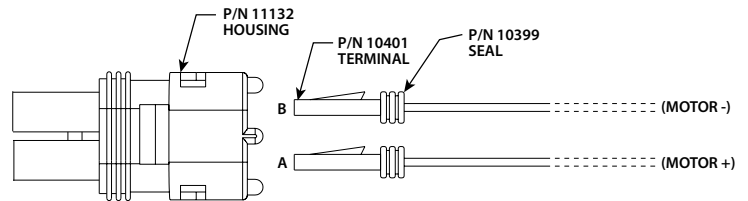

Kit 18108 Parts List

Part	Qty.	Description
18104	1	10A PWM EMD Module
17539	1	Adapter Cable
14501	1	Motor Extension Cable 5'
18137	1	Power Cable 20'
13200	1	PWM Control Cable 5'
11132	1	2-pin W/P Tower Housing
10401	2	W/P Terminals
10399	2	W/P Seal

Module Connectivity

⚠ IMPORTANT! ⚠
 Do **not** connect the motor leads to the battery or power supply. Resulting damage to controller will **not** be covered under warranty.

Motor Connection:
 2-pin W/P shroud
Connects to:
 PN14501 Motor Cable

Power Connection:
 3-pin W/P shroud
Connects to:
 PN18137 20' Power Cable

Control Connection:
 2-pin M/P150 shroud
Connects to:
 PN13200 5' PWM Cable

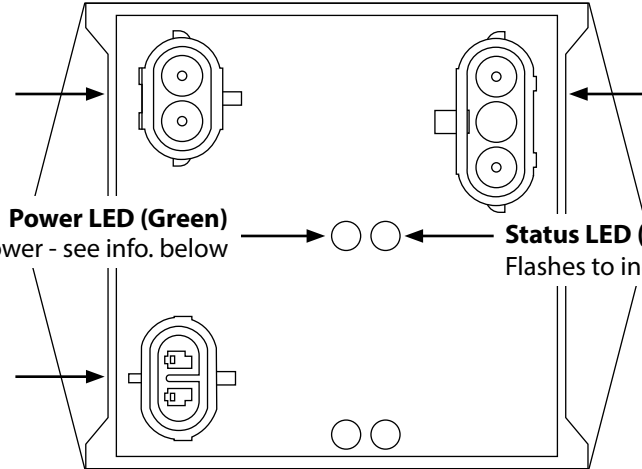

Power LED (Green)
 Flashes to indicate power - see info. below

Status LED (Red)
 Flashes to indicate status - see info. below

Control Signal LEDs

Green: On when control signal is present and increasing
Red: On when control signal is present and decreasing

4 LED MODELS: (2020 & after)

Power LED (Green):

LED on steady Unit turned on and operating normally
 1 Flash/pause Unit in **HOLD**.

⚠ After 5 consecutive minutes in **HOLD** position, the Power LED will automatically turn off & stay off until module is in **RUN** again.

Status LED (RED):

flashing code repeats every 4 sec. - cycle controller power to clear fault code

2 Flashes/pause	Output short circuit detected. Check motor connections.
3 Flashes/pause	Over-current condition. Check total load.
4 Flashes/pause	Input power fault. Check input voltage and/or power wiring.
5 Flashes/pause	PWM control input frequency out of range. Check settings.
6 Flashes/pause	Internal processor fault.
7 Flashes/pause	Thermal shutdown fault. Unit is overheated.

⚠ Cycle power with controller ON/OFF switch to clear a fault code.

3 LED MODELS: (2020 & before)

Single Status LED:

flashing code repeats after pause - cycle controller power to clear fault code

LED on steady	Unit turned on and operating normally
Steady Flashing	Unit in HOLD . Check Run/Hold switch or remote switch on controller.
1 Flash/pause	Open circuit detected. Check motor connections for open.
2 Flashes/pause	Output short circuit detected. Check motor connections.
3 Flashes/pause	Over-current condition. Check total load.
4 Flashes/pause	Input power fault. Check input voltage and/or power wiring.
5 Flashes/pause	PWM control input frequency out of range. Check settings.

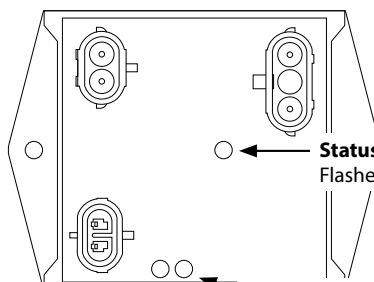

Status LED (Red)
 Flashes to indicate status - see info. above

Control Signal LEDs

Green: On when control signal is present and increasing
Red: On when control signal is present and decreasing