



10 Amp STD Electric Motor Driver

Electric Motor Driver (EMD) Module

10 AMP MAXIMUM

The Electric Motor Driver Module (EMD) replaces the servo valve. System flow is controlled by regulating the pump speed.

MODULE INSTALLATION

NOTE: The mounting surface must be cleaned so it is free from dirt, moisture and oil residues. Failure to clean the mounting surface may result in the EMD working loose.

Remove the backing from the Dual-Lock™ fasteners and attach to the bottom of the EMD unit. Position the EMD where wiring will work the best. Extension cables are available. Firmly press the EMD into place. Secure the EMD to the equipment using plastic cable ties to prevent the EMD from coming into contact with moving parts if the Dual-Lock™ fasteners should work loose. If desired, the EMD can be fastened with screws, using the holes in the mounting flanges.

ELECTRICAL INSTALLATION

This section explains how to hook-up your EMD to a 12-volt power connection, and how to connect your EMD to your controller harness.

The EMD **MUST** be connected to a 12-volt DC negative ground electrical system.

POWER BATTERY CONNECTION

Locate the power cable, P/N 18137 and route to the battery. In routing cable avoid areas where the cable may be subjected to abrasion or excessive heat. Attach the BLACK wire to ground. See Illustration to the upper right. Be sure there is a good metal-to-metal contact. Connect the ORANGE wire to the positive battery terminal.

Connect the power to the EMD by plugging the 3-pin W/P tower on the power cable into the 3-pin W/P shroud of the EMD module.

SIGNAL AND MOTOR CONNECTIONS

Locate the boom wire, P/N 14500. Plug the 2-pin W/P shroud into the mating connector on the EMD module and plug the quick-disconnect into the mating connector on the BROWN wire (if connecting to a SprayMate system) or the YELLOW wire (if connecting to an MT-3405F or an MT-9000 system) on the controller harness.

Note: the +12 VDC signal is required to turn the EMD on.

NOTE: Be sure to route cables away from sharp edges, areas of high heat and moving parts. Secure all cables firmly with plastic cable ties.

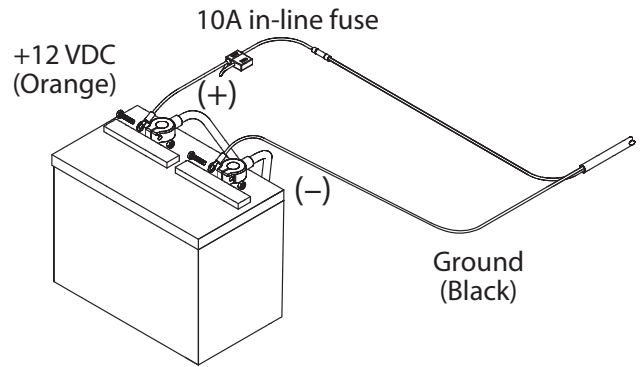

Locate the servo cable P/N 10450. Connect the 3-pin W/P shroud to the 3-pin W/P tower on the EMD module. Connect the other end of the cable to the mating connector on the controller harness as shown.

Locate the motor cable P/N 14501. Plug the 2-pin W/P tower into the 2-pin W/P shroud on the EMD module. A mating connector is supplied to connect to the motor, or the connector on the pump cable can be removed and wire-to-wire connection can be made. Insure that the pump is running in the correct direction. If not, simply reverse the wires from the pump to the pump cable.

See next page for applicable diagram.

NOTE: MICRO-TRAK CONSOLE MUST BE SET FOR "BYPASS" OPERATION.

FUNCTION OF CONTROL SIGNAL STATUS LEDS

- Green LED lights when servo signal is present and increasing
- Red LED lights when servo signal is present and decreasing

LED STATUS INDICATOR CODES

See table on page two for LED status indicator code explanations.



LED STATUS INDICATOR CODES		
Light on steady		Unit is turned on and operating normally
Steady Flashing		Unit in HOLD. Check Run/Hold jumper or remote switch for correct operation.
1 Flash/pause		Open circuit detected. Check motor connections for open.
2 Flashes/pause		Output short circuit detected. Check motor wiring.
3 Flashes/pause		Over-current condition. Check total load.
4 Flashes/pause		Input Power fault. Check input power wiring.

NOTE: Cycle power with the controller ON/OFF switch to clear a fault code

Module Diagram

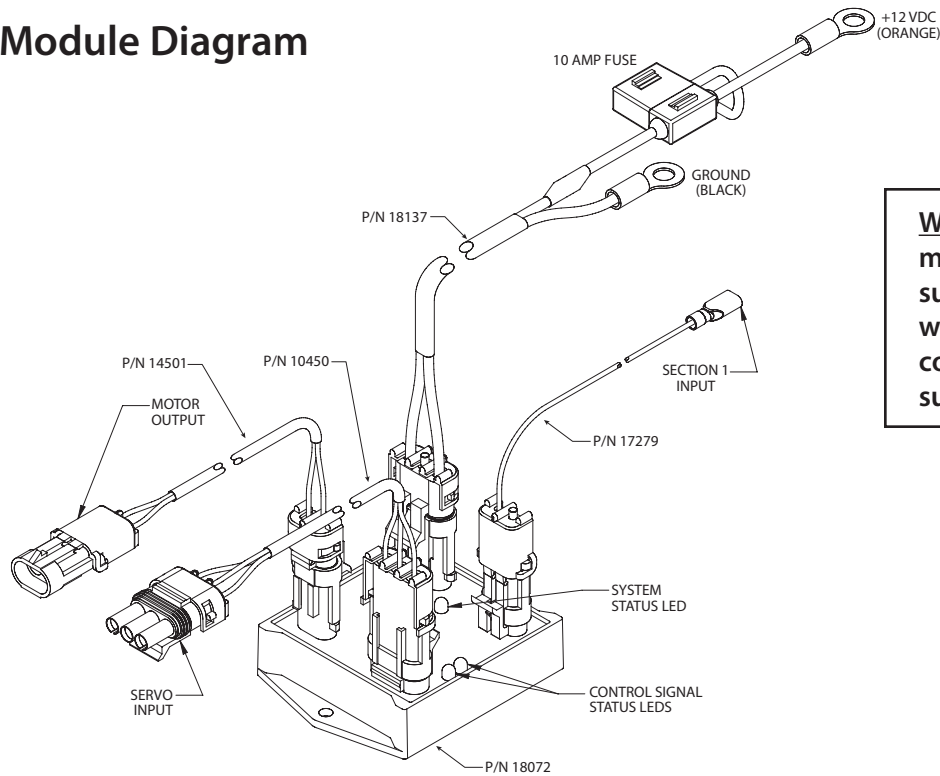

MATING CONNECTOR
HOUSING (1) P/N 11132
SEALS (2) P/N 10399
TERMINALS (2) P/N 10401

WARNING: Do NOT connect the motor leads to the battery or power supply. Non-warranty damage will result if the motor leads are connected to the battery or power supply.

