



40 Amp PWM Electric Motor Driver with Enable Feature

The Electric Motor Driver Module (EMD) replaces the servo valve. System flow is controlled by regulating the pump speed via a PWM signal to the EMD.

NOTE: This unit will ONLY work with PWM (Pulse Width Modulated) Control drives. Set the PWM frequency of your controller to 150 Hz.

NOTE: MICRO-TRAK CONSOLE MUST BE SET FOR "BYPASS" OPERATION.

MODULE INSTALLATION

NOTE: The mounting surface must be cleaned so it is free from dirt, moisture and oil residues. Failure to clean the mounting surface may result in the EMD working loose.

Remove the GREEN backing from the Dual-Lock™ fasteners on the bottom of the EMD unit. Position the EMD where wiring will work the best. Extension cables are available. Firmly press the EMD into place. Secure the EMD to the equipment using plastic cable ties to prevent the EMD from coming into contact with moving parts if the Dual-Lock™ fasteners should work loose. If desired, the EMD can be fastened with screws, using the holes in the mounting flanges.

ELECTRICAL INSTALLATION

This section explains how to hook-up your EMD to a 12-volt power connection, and how to connect your EMD to your controller harness.

The EMD **MUST** be connected to a 12-volt DC negative ground electrical system.

POWER BATTERY CONNECTION

Locate the power cable, P/N 18419 and route to the battery. In routing cable avoid areas where the cable may be subjected to abrasion or excessive heat. Attach the BLACK wire to ground. See illustration to the upper right. Be sure there is a good metal-to-metal contact. Connect the RED wire to the positive battery terminal.

Connect the power to the EMD by plugging the 2-Pin M/P 480 Tower on the power cable into the 2-Pin M/P 480 Shroud of the EMD module.

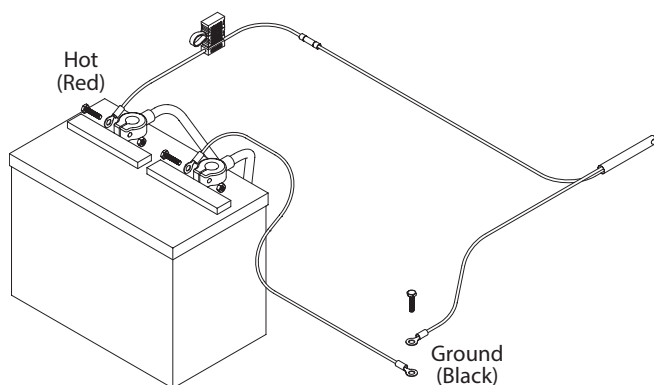

SIGNAL AND MOTOR CONNECTIONS

NOTE: Be sure to route cables away from sharp edges, areas of high heat and moving parts. Secure all cables firmly with plastic cable ties.

Connect PWM input to the 2-pin M/P connector on the module, using Adapter Cable P/N 17539 if required.

Locate the pump cable P/N 18420. Plug the 2-pin M/P 480 Shroud into the 2-pin M/P 480 Tower connection on the EMD module. Connect the other end to the pump. Insure that the pump is running in the correct direction. If not, simply reverse the wires from the pump to the pump cable. See next page for diagram.

ENABLE CONNECTION

This 2-pin W/P connection provides an "instant-on" feature. It is triggered by a 12VDC input signal from a controller or other device applied to pin A of connector. A switch or relay circuit could also be installed between pins A and B to activate the Enable feature.







Connect Micro-Trak controllers with "Multifunction" output to this connection for flow trigger functions (use P/N 17279 Enable Adapter).

If not using Enable feature, included jumper P/N 18111 **must** be installed.

CONTROL SIGNAL STATUS LEDS (only one of the two LEDS will light)

LED unlit when no signal is present - glows brighter as signal increases; dims as signal decreases.

LED STATUS INDICATOR CODES

| | | |
|-----------------|---|---|
| Light on steady |  | Unit is turned on and operating normally |
| Steady Flashing |  | Unit in HOLD. Check Run/Hold jumper or remote switch on controller for correct operation. |
| 1 Flash/pause |  | Open circuit detected. Check motor connections for open. |
| 2 Flashes/pause |  | Output short circuit detected. Check motor wiring. |
| 3 Flashes/pause |  | Over-current condition. Check total load. |
| 4 Flashes/pause |  | Input Power fault. Check input power wiring. |
| 5 Flashes/pause |  | Input frequency out of range. |

NOTE: Cycle power with the controller ON/OFF switch to clear a fault code

Module Diagram

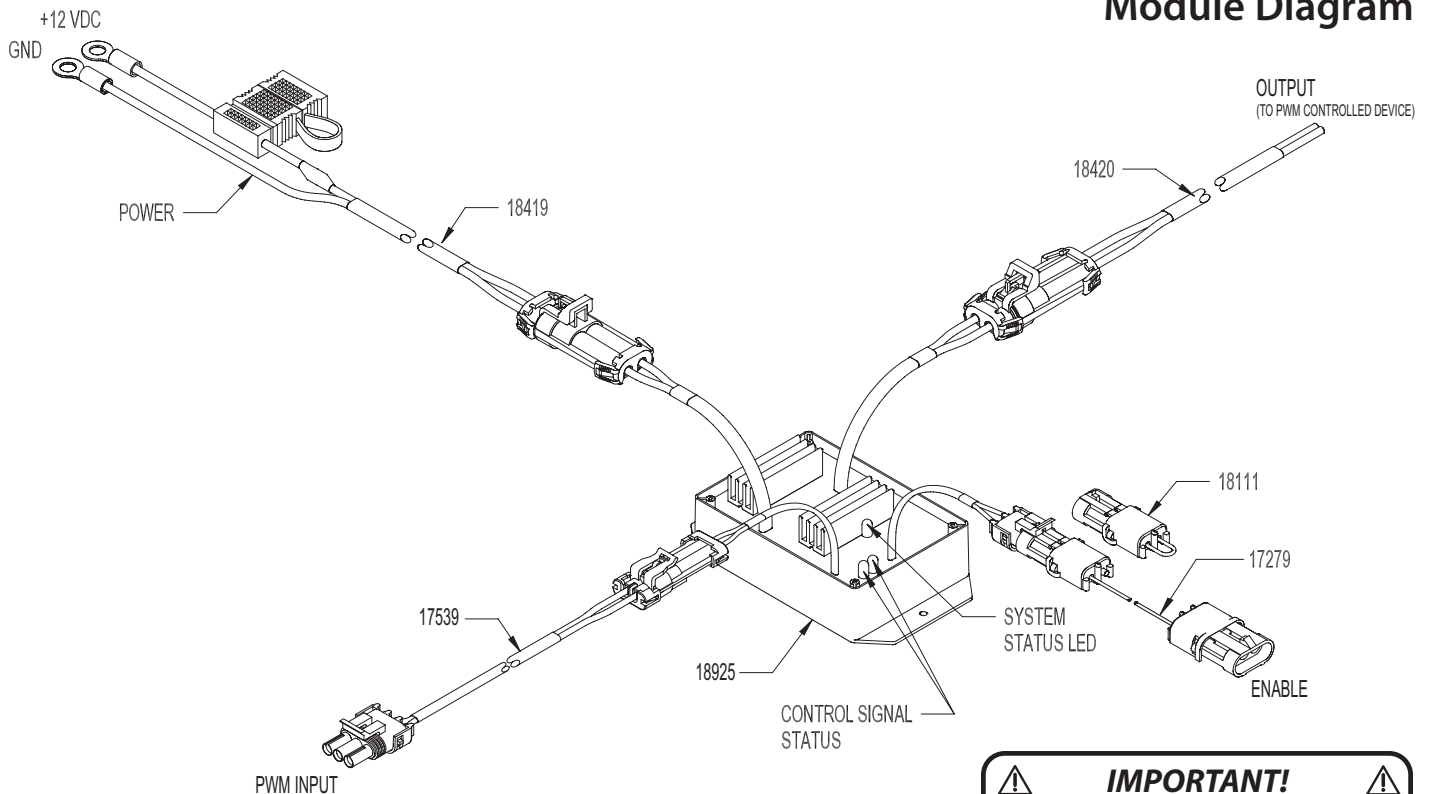

⚠ IMPORTANT! ⚠
 Do **not** connect the output leads to the battery or power supply. Resulting damage to controller will **not** be covered under warranty.